

NOTES:

1. ALL DIMENSIONS ARE IN INCHES [MILLIMETERS].
2. NET WEIGHT IS 17.78 LBS [8.08 kg]
3. LENGTH OF THE CORD IS 36 INCHES [914 mm].
4. UNIVERSAL MOUNTING BRACKET IS AN ALTERNATIVE MOUNTING METHOD TO THE TOOLLESS MOUNT FOR NON APC RACKS.
5. BRACKET KITS TO MOUNT TO SPECIFIC COMPETITORS RACKS ARE AVAILABLE AS OPTIONS.
6. INSTALLATION MUST COMPLY WITH ALL APPLICABLE NATIONAL AND LOCAL CODES.

ASH-024-C-35A-CS

TITLE: RACK PDU, SWITCHED  
 ZERO U, 12.5kW, 208V, INPUT: CS8365C  
 OUTPUT: (21)IEC 320 C13, (3)IEC 320 C19  
 MAIN MECHANICAL

PROJECT: SUBMITTAL DRAWING SHEET 1 OF 2

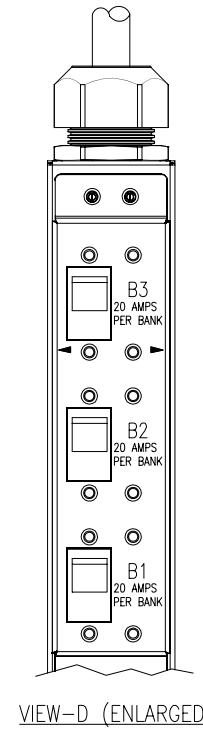
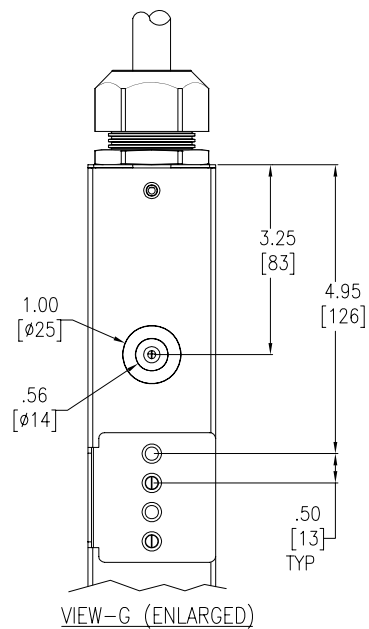
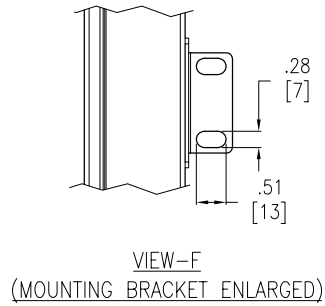
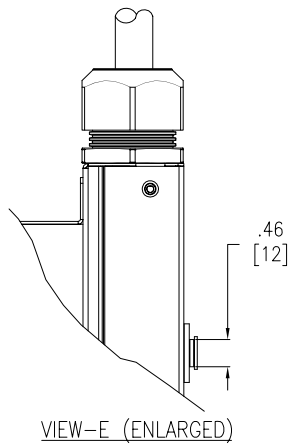
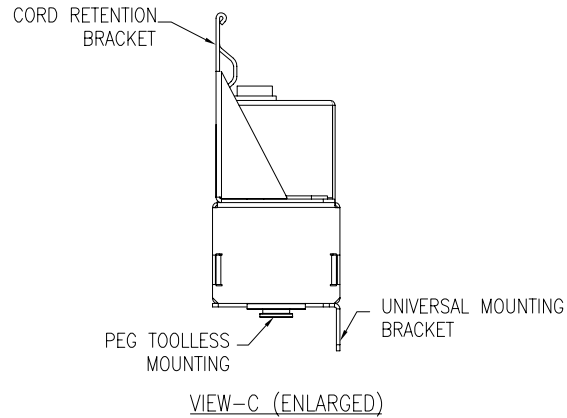
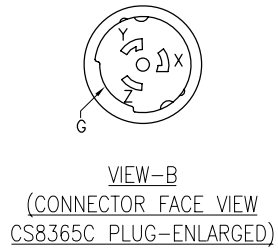
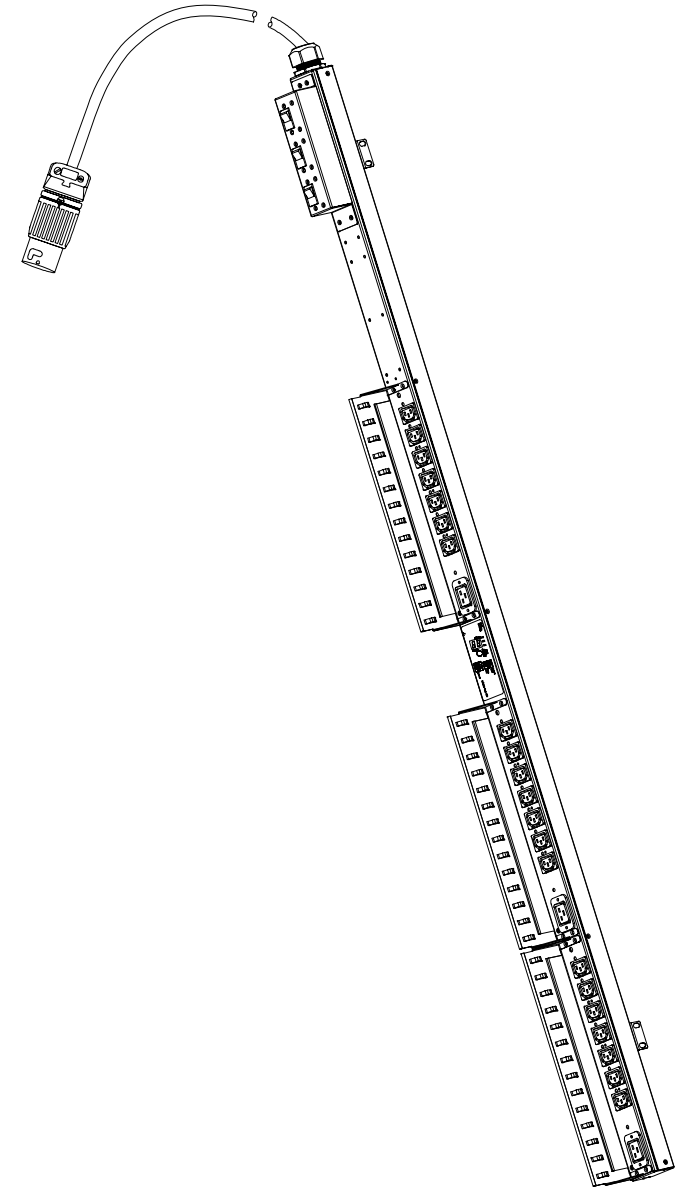
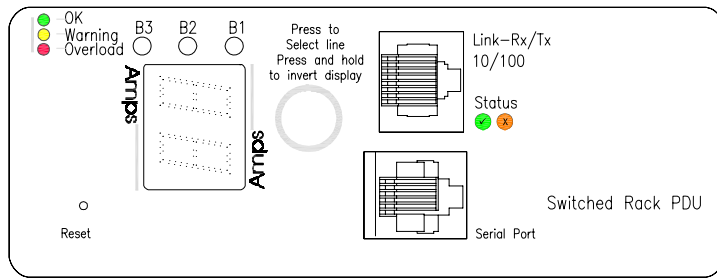

NOTES:

1. ALL DIMENSIONS ARE IN INCHES [MILLIMETERS].
2. INSTALLATION MUST COMPLY WITH ALL APPLICABLE NATIONAL AND LOCAL CODES.

ASH-024-C-35A-CS

TITLE: RACK PDU, SWITCHED  
 ZERO U, 12.5KW, 208V, INPUT: CS8365C  
 OUTPUT: (21)IEC 320 C13, (3)IEC 320 C19  
 DETAILS & ISOMETRIC VIEW

PROJECT: SUBMITTAL DRAWING SHEET 2 OF 2

 **Synergy Global Technology Inc**  
[www.RackmountMart.com](http://www.RackmountMart.com)