



Toll Free: 1-888-865-6888

Tel: 510-226-8368 Fax: 510-226-8968

Email: sales@RackmountMart.com

Triple Screen LCD Console Drawer Dual Rail

LCD2U17-3H-01



This manual, covering various aspects of the equipment such as installation and setup, which will help you make full use of this LCD Drawer. Please read this manual carefully, install and operate the equipment according to the manual to avoid damage.

Product package includes following items:

- 1 * Triple screen LCD drawer;
- 1 * AC Power Cord
- 1 * Rack installation bracket (one pair)
- 1 * USER'S manual (CD)
- 3 * 1.8 Meter VGA cable
- 3 * 1.8 Meter DVI cable
- 1 * 1.8 Meter USB A Type cable
- 1 * 1.8 Meter Audio cable

Please check items above. If any item is missing or damaged, please contact your dealer promptly.

Table of Contents

1	Introduction	-4-
	1.1 Overview	-4-
	1.2 Functions & Features	-4-
	1.3 Hardware Requirement	-4-
	1.3.1 Host Requirement	-4-
	1.3.2 Cables	-4-
	1.4 Product Specifications	-5-
	1.5 LCD Specifications	-5-
	1.6 Front View	-6-
	1.7 Rear View	-7-
2	Installation	-8-
	2.1 Rack Installation	-8-
	2.2 Operation	-9-
	2.3 Standard Installation	-10-
	2.4 LCD OSD Menu Setup	-11-
3	Certificates	-12-

1 Introduction

1.1 Overview

LCD2U17-3H-01 LCD integrates keyboard, 3 x LCD display and touch pad in a drawer type worktable and provides a convenient space-saving operation mode. Dual rail design allows LCD screen and keyboard tray operated independently.

With a graphic card, screen can be cloned or extended to each screen; or can display independently. With screen extended function, people can be multi-tasking in different screens. When operating, mouse can simply cross each screen boundary.

1.2 Function & Features

LCD2U17-3H-01 is 2U height, supported resolution up to 1920 x 1200 , 75Hz. It can be installed into 19 inch rack cabinet . No need to install additional software or hardware.

1.3 Hardware Requirement

1.3.1 Hosts Requirement:

- (1) DVI, VGA graphic card

Note: the max. resolution of the integrated LCD display is 1920x1200. Make sure the resolution of any connected computer does not exceed this resolution.

- (2) USB port for keyboard and mouse.
- (3) USB 2.0 Hub for peripheral USB device

1.3.2 Cables

- (1) 3x DB-15 VGA cable male to male
- (2) 1x USB A Type Cable
- (3) 3x DVI-D Cable male to male
- (4) 1x Audio Cable

1.4 Product Specifications

Model		LCD2U17-3H-01
Brightness		300cd/m2
Contrast		650:1
Angle of visibility		140°(H),120°(V)
Color display		262K
Video resolution		native 1920 x 1080 (support up to 1920 x 1200)
Keyboard		104 keys
Mouse		touch pad mouse
Local Control Terminal (Master)	Keyboard/Mouse	USB 2.0
	DVI-D	24 pin DVI-D female connector
	VGA	HD-15 female connector
	USB 2.0	For USB peripheral device
	Audio	3.5mm stereo jack
Local Control Terminal (Slave 1)	DVI-D	24 pin DVI-D female connector
	VGA	HD-15 female connector
Local Control Terminal (Slave 2)	DVI-D	24 pin DVI-D female connector
	VGA	HD-15 female connector
Power supply		100-240V AC 50/60Hz via IEC Type power cord
Housing		Metal housing
Weight		18.5Kg
Dimension(W x H x D)		443 x 88 x 580 mm

1.6 Front View

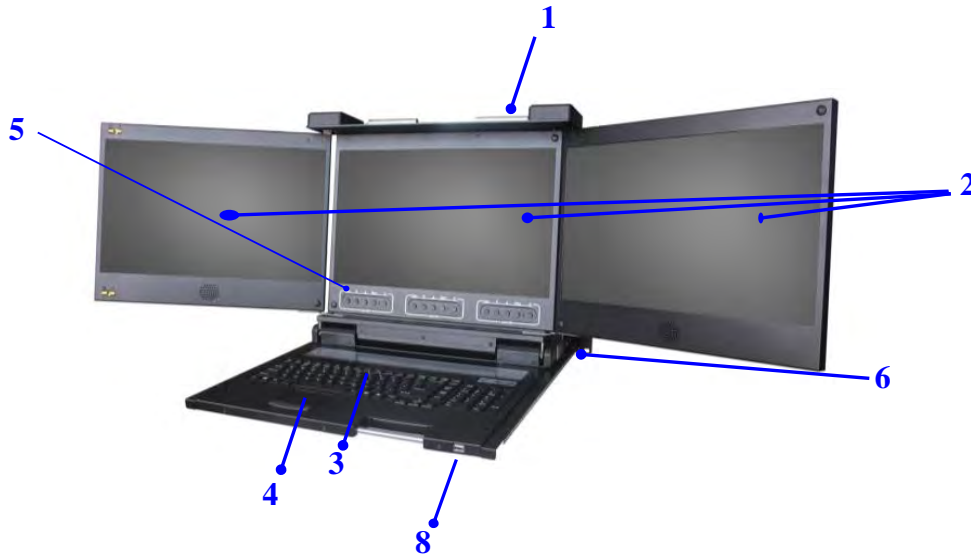

NO	Part	Function Description
1	Handle to adjust screen tilt; lock/release rail sliding	
2	LCD display	
3	Keyboard	
4	Touchpad	
5	LCD OSD button	LCD button to control Screen Display position and image setting.
6	Mounting bracket	Install into rack cabinet
7	Lock button	Auto lock / release when lcd pull up and down
8	USB2.0 HUB port	

1.7 Rear View

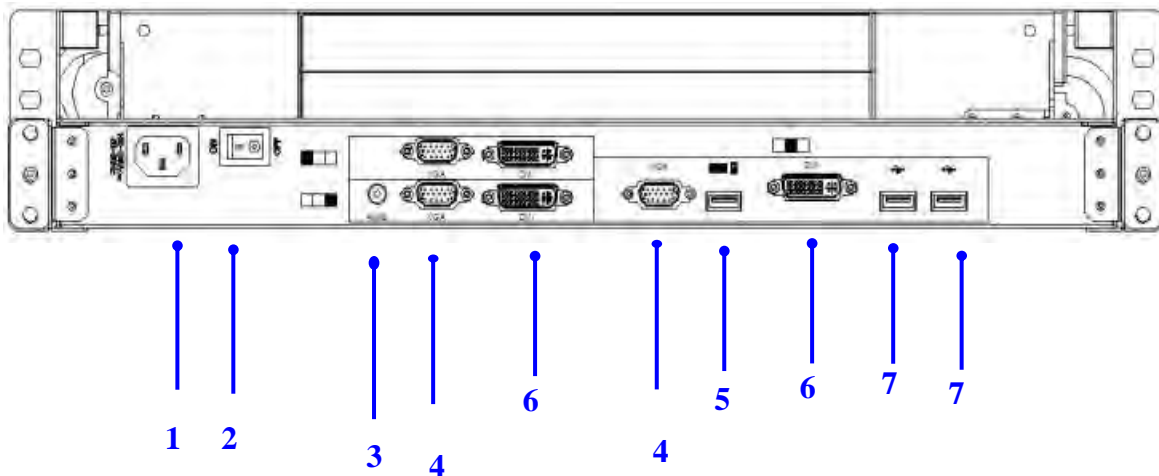

No	Component	Function Description
1	AC Power port	Standard IEC Type AC Inlet
2	Power Switch	Rock switch, turn on/off equipment main power.
3	Audio port	For audio function
4	VGA port	Connect to server or KVM.
5	USB port	Connect to server or KVM.
6	DVI port	Connect to server or KVM.
7	USB 2.0	For USB peripheral device

2 Installation

2.1 Rack Installation

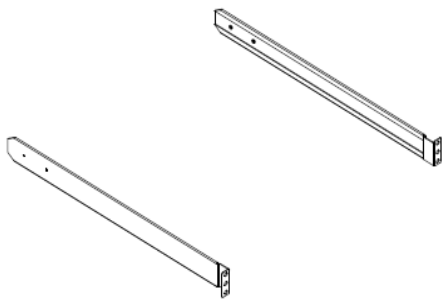

Front mounting bracket (L&R)

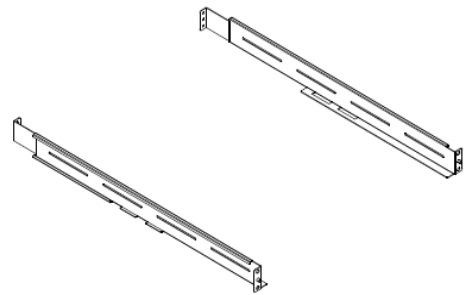

Rear mounting bracket (L&R)

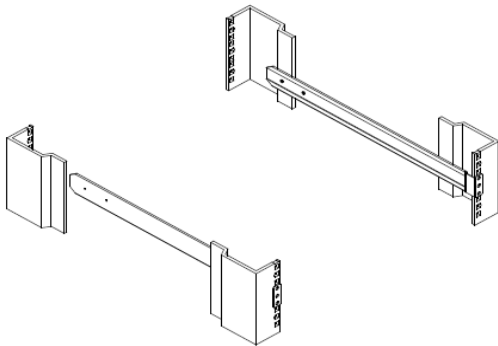

Step 1 Back View

- Rear mounting bracket, screw M6 *4pcs

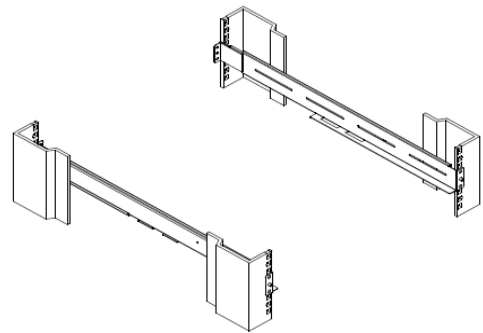

Step 2 Front View

- Insert the left and right front mounting brackets into rear mounting bracket, screw M6 * 4pcs

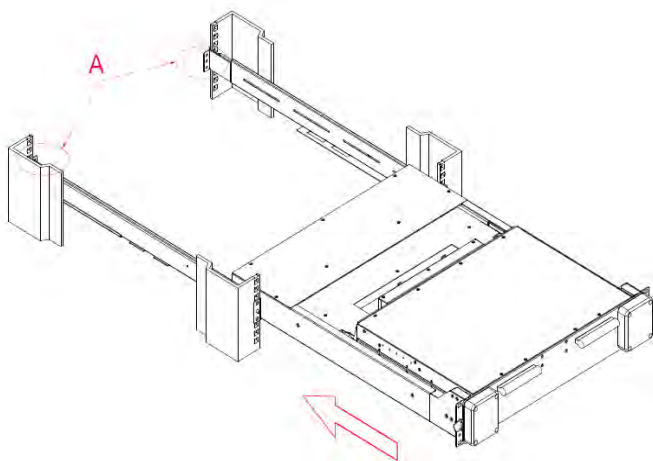

Step 3 Front View

- Slide KVM into mounting bracket
- Screw M4 *4pcs at Point A

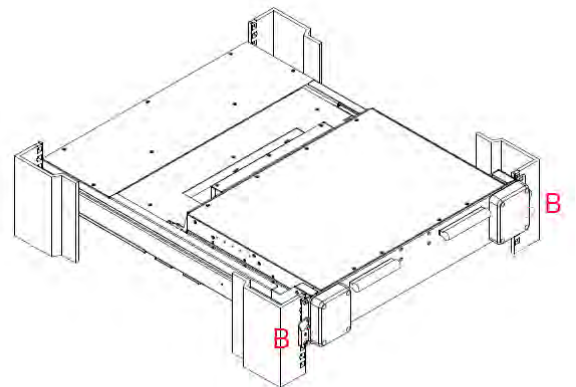

Step 4 Front View

- Screw M4 *2pcs at Point B

2.2 Operation

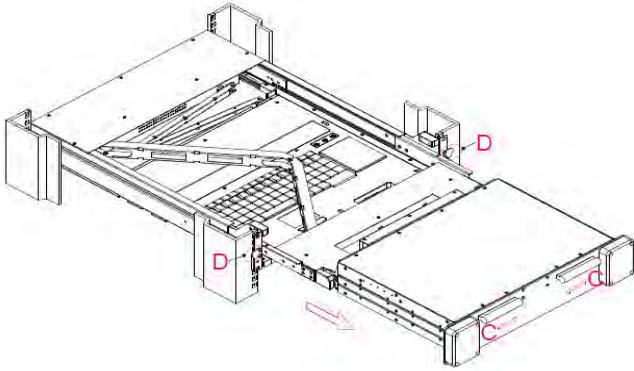

Step 1

- Unlock handle C to release rail locker and slide out
- Use locker D to stable the rail

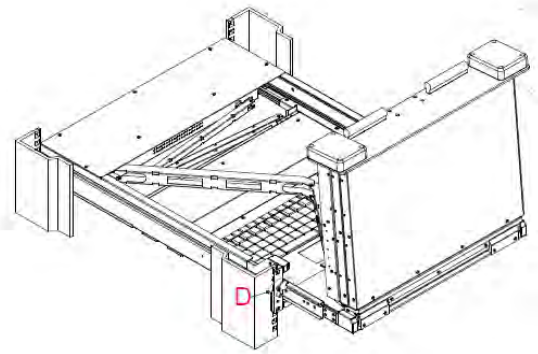

Step 2

- Lift up LCD panel

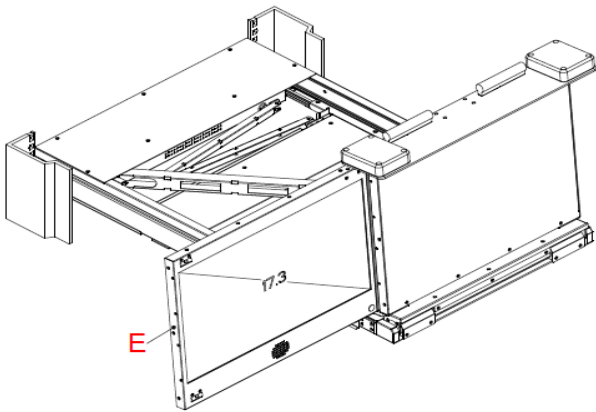

Step 3

- Hold Point E to open the left panel

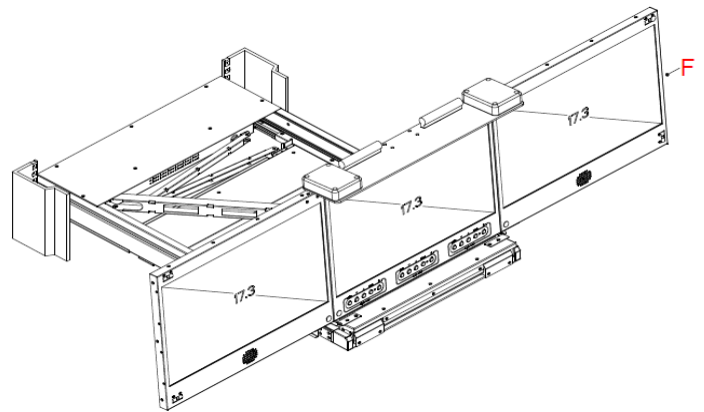

Step 4

- Hold Point F to open the right panel

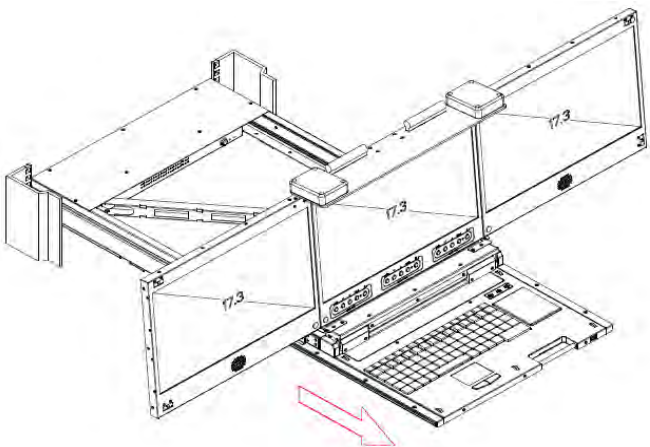

Step 5

- Slide out keyboard tray when needed

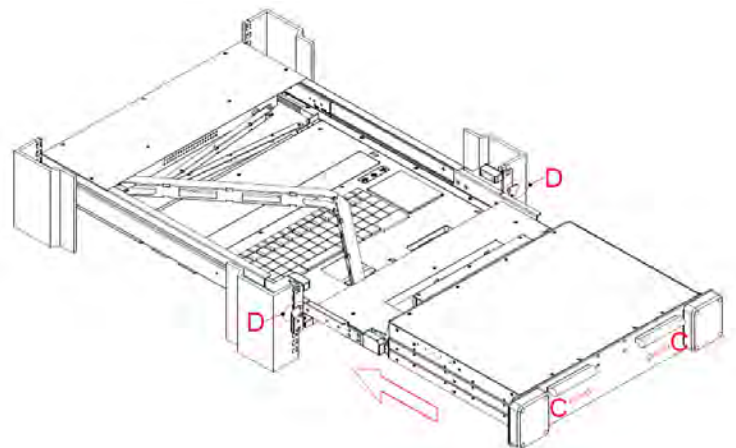

Step 6 After operation

- Based on step 5 --- 4 --- 3 --- 2 to put away keyboard tray and LCD panels
- Unlock locker D
- Use handle C to lock into cabinet

2.3 Standard Installation

Please follow the installation drawing and instructions below for standard installation:

- * Please Shutdown the Power of Equipment Needs to be Connected
- * Please Pay Attention to Earthing of Equipment

The standard installation is completed, and LCD KVM console can be powered on. Then power on connected hosts.

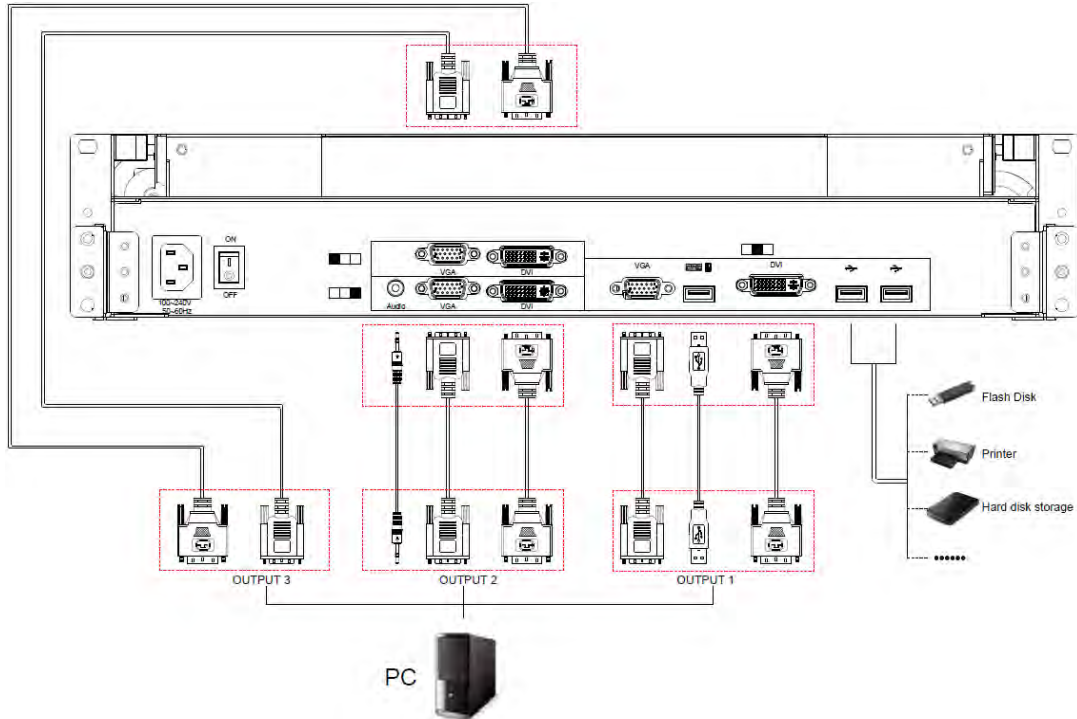

Demonstration of Different Display Mode



Extend



Clone



Independent

2.4 LCD OSD Menu Setup

OSD Control buttons

LCD OSD can establish and setup LCD display. Setup instructions of four buttons are as follows:

Button	Functions
POWER	Turn on or off the LCD Display
MENU	Activate OSD menu, select a menu and press MENU key to confirm the selection and enter the submenu.
▲	Press this key to increase setting or scroll up the menu bar
▼	Press this key to Decrease setting or scroll down the menu bar
AUTO	press the auto key to select video source

OSD Control Operation

Main Menu



3 Certificates

FCC

This product has been tested and is proved to meet requirements of Grade B electronic devices and specifications of Section 15 of FCC certification. Please observe following two conditions in operation that:

- (1) The equipment will not generate any harmful interruption.
- (2) If the equipment is interrupted, it may cause unnecessary operations.

CE

This equipment complies with regulations of EN55022:CLASS B.

RoHS

The whole package including products, packaging materials and documents meet RoHS equipments.

The company reserves the right to modify product specifications without prior notice and assumes no responsibility for any error which may appear in this publication.

All brand names, logo and registered trademarks are properties of their respective owners.

Copyright 2022 Synergy Global Technology Inc. All rights reserved.