

Nova 2U Rack Mount Triple Monitor KVM Console Drawer



The NOVA 2U triple display console drawer is designed for Command and Control Systems which demand quick deployment of side by side displays.

2U short depth platform allows for small size and transit case portability. To ensure chassis ruggedness, mobility and quality, as well as being suitable for harsh environment applications, the NOVA drawer is meticulously constructed by a team of experts in our own CNC facilities for such applications.

The key benefit of the NOVA series is the choice of different resolution panels including 4K 17", WUXGA 16.2", FHD 17" 60Hz, 19" 4:3 LED backlit displays. Sunlight Readable FHD 17" and 19" 4:3 LCD is also available. 4K 17" displays satisfy the increasing demands for higher graphical and text requirements. A solid 104 key keyboard is integrated with either touchpad or trackball.

Key Benefits

- ▶ 2U 22" short depth design (19" is 23.6" deep)
- ▶ Light weight
- ▶ Rugged construction for mobility & durability
- ▶ Built-in solid bearing slide rails
- ▶ Built-in dual stereo speaker (per display)
- ▶ Four LED backlit display selections (4K 17", WUXGA 16.2", FHD 17", 4:3 19")
- ▶ DVI-D + VGA video input for WUXGA, FHD & 4:3 (per display)
- ▶ Display port 1.2 video input for 4K (per display)
- ▶ 104-key keyboard with either touchpad or trackball (PS2 / USB)
- ▶ Fits 24" ~ 36" rack via adjustable mounting brackets

Options

- DC power : 12V / 24V / 48V / 110V / 125V / 250V
- 3G / HD / SD-SDI Broadcast-grade input
- Sunlight readable LCD for FHD 17" & 4:3 19"
- Touchscreen
- Front USB hub port for device access
- HDMI video input
- MAC or SUN Micro keyboard
- USB keyboard & mouse selector

Models



17" **4K**

LCD2U17-3K-02

17" **1080p 60 Hz**

LCD2U17-3H-02 / LCD2U17-3H-03 (High Bright)

16.2" **1920 1200**

LCD2U17-3X-02

19" **1280 1024**

LCD2U19-3T-02 / LCD2U19-3T-03 (High Bright)

Product Specifications

LCD Panel	LCD2U17-3K-02	LCD2U17-3H-02	LCD2U17-3H-03	LCD2U17-3X-02	LCD2U19-3T-02	LCD2U19-3T-03
Native resolution	3840 x 2160@60Hz	1920 x 1080	1920 x 1080	1920 x 1200	1280 x 1024	1280 x 1024
Panel size (diagonal)	17.3"	17.3"	17.3"	16.2"	19"	19"
Refresh rate (Hz)	60	60	60	60	60 / 75	60 / 75
Standard Brightness (cd/m ²)	400	300	1000	300	250	1000
Contrast ratio (typ.)	1000 : 1	1000 : 1	600 : 1	800 : 1	1000 : 1	1000 : 1
Colors	16.7 M, 8-bit	16.7 M, 8-bit	16.7 M, 8-bit	16.7 M, 8-bit	16.7 M	16.7 M
Viewing angle (L/R/U/D)	89/89/89/89	85/85/85/85	80/80/60/80	89/89/89/89	85/85/80/80	85/85/80/80
Response time (ms)	Max. 16	25	25	30	5	5
Dot pitch (mm)	0.0995	0.1989	0.1989	0.191	0.294	0.294
Display area (mm)	382.12H x 214.94V	381.888H x 214.812V	381.888H x 214.812V	383.8H x 214.9V	337.92H x 270.33V	337.92H x 270.33V
Surface treatment	Anti-glare	Anti-glare, Hard-coating	Anti-glare, Hard-coating	Anti-glare, Hard-coating	Haze 25%, Hard-coating	Haze 25%, Hard-coating
Surface hardness	3H					
Backlight type	LED					
MTBF (hrs)	15,000	15,000	50,000	20,000	30,000	30,000

Video	LCD2U17-3K-02	LCD2U17-3H-02	LCD2U17-3H-03	LCD2U17-3X-02	LCD2U19-3T-02	LCD2U19-3T-03
Package	DP 1.2 / HDCP 1.3 <i>* attached 6ft DP cable</i>	DVI-D + VGA	DVI-D + VGA	DVI-D + VGA	DVI-D + VGA	DVI-D + VGA
Option	HDMI 2.0 / HDCP 2.2	HDMI 1.4 / HDCP 1.4 or DP 1.0 / HDCP 1.3	HDMI 1.4 / HDCP 1.4 or DP 1.0 / HDCP 1.3	HDMI 1.4 / HDCP 1.4	HDMI 1.2 / HDCP 1.1	HDMI 1.2 / HDCP 1.1

Capacitive Touch screen Option

	LCD2U17-3K-02	LCD2U17-3H-02	LCD2U17-3H-03	LCD2U17-3X-02	LCD2U19-3T-02	LCD2U19-3T-03
Technology	Projected Capacitive				Capacitive	Capacitive
Touch Point	10 point touch standard				Single	Single
Input Type	Finger or Capacitive Stylus				Finger	Finger
Resolution	4096 x 4096				2048 x 2048	2048 x 2048
Touch Point Accuracy	± 2 mm				-	-
Response Speed	< 5 ms				20 ms	20 ms
Activation Force	< 5 g				≤ 50 g	≤ 50 g
Surface Hardness	6H				9H	9H
Light Transmission	> 85%				92% ± 2%	92% ± 2%
Haze	3%↓				7%	7%
Durability	50 million touches				300 million touches	300 million touches
Top Layer	1.8 mm Glass				Glass	Glass
Bottom Layer	0.7 mm Sensor Glass					
Thickness	2.7 mm ± 0.1 mm				2.8 mm ± 10%	2.8 mm ± 10%
Connector	USB				USB Type A	USB Type A
Compatibility	Windows 7 / XP / Linux / Mac					

Resistive Touch screen Option

	LCD2U17-3K-02	LCD2U17-3H-02	LCD2U17-3H-03	LCD2U17-3X-02	LCD2U19-3T-02	LCD2U19-3T-03
Technology	5-Wire Resistive					
Touch Point	Single					
Input Type	Finger or Stylus					
Resolution	2048 x 2048					
Response Speed	15 ms					
Activation Force	≤ 50 g					
Surface Hardness	3H					
Light Transmission	80% ± 3%					
Haze	8% ± 3%					
Durability	10 million touches					
Top Layer	ITO Film					
Bottom Layer	ITO Glass					
Thickness	3.2 ± 0.2 mm	2.2 ± 0.2 mm	2.2 ± 0.2 mm	3.2 ± 0.2 mm	2.2 ± 0.2 mm	2.2 ± 0.2 mm
Connector	USB Type A					
Compatibility	Windows 7 / XP / Linux / Mac					

Product Specifications

LCD Panel		LCD2U17-3K-02	LCD2U17-3H-02	LCD2U17-3H-03	LCD2U17-3X-02	LCD2U19-3T-02	LCD2U19-3T-03
Input		Auto-sensing 100 to 240VAC, 50 / 60Hz					
Consumption per panel	Screen on	Max. 21W	Max. 14W	Max. 39W	Max. 25W	Max. 22W	Max. 35W
	Power saving	Max. 2W				Max. 4W	
	Power button off	Max. 1W				Max. 1W	

Physical			
Product (W x D x H)	3K/3H/3X model	mm inch	441.6 x 550 x 88 17.4 x 21.7 x 3.5
	3T	mm inch	441.6 x 600 x 88 22.8 x 23.6 x 7.8
Net Weight	3K/3H/3X model	Triple display	25.7 kg / 56.5 lb
	3T	Triple display	26.7 kg / 58.7 lb
Chassis color		Dark	
Chassis materials		Steel	

Compliance	
EMC	FCC & CE
Safety	CE / LVD & UKCA
Environment	REACH & RoHS3 / WEEE

Environment	
Operating temp.	0 to 55°C degree
Storage temp.	-20 to 60°C degree
Operating humidity	10~90%, non-condensing
Storage humidity	5 ~90%, non-condensing
Operating altitude	16,000 ft
Non-operating altitude	40,000 ft
Shock	10G acceleration (11ms duration)
Vibration	10~300Hz 0.5G RMS random vibration

* All dimensions stated are subject to change if options are selected / integrated to base model part codes

USB Keyboard & Mouse Selector

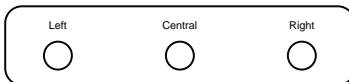

- Enables 2 or 3 computers to share keyboard & mouse.
- Easily switch to any of your connected computers with the press of a button

Standard Keyboard

N keyboard integrated with touchpad

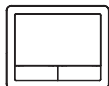

B keyboard integrated with trackball

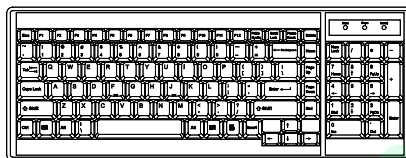

Supporting layouts

America						
	U.S.					
EMEA						
	U.K.	Germany	France	Russia	Spain	Italy
	Asia					
		Japan	Korea			

Keyboard Options

* US layout only

Mn Mac keyboard with touchpad



Sn SUN keyboard with touchpad

Mb Mac keyboard with trackball

Sb SUN keyboard with trackball



Nova 2U Rack Mount Triple Monitor KVM Console Drawer

Diagrams (mm)

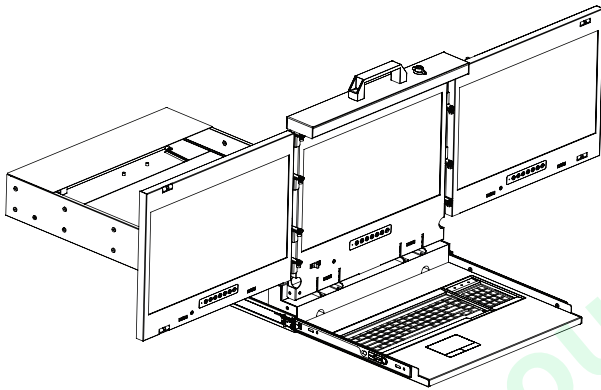

Front View

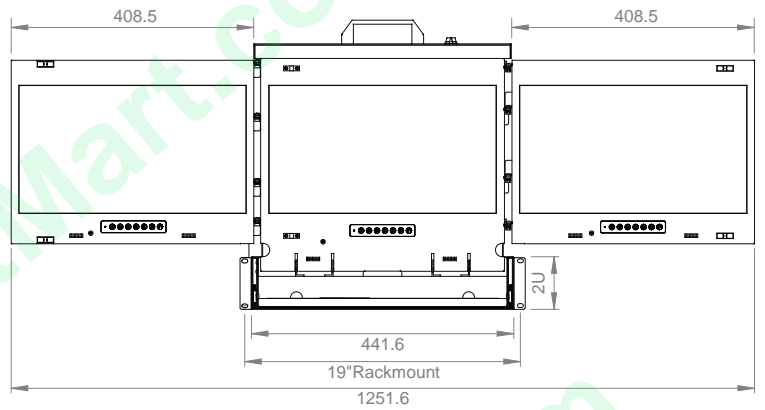

Side View

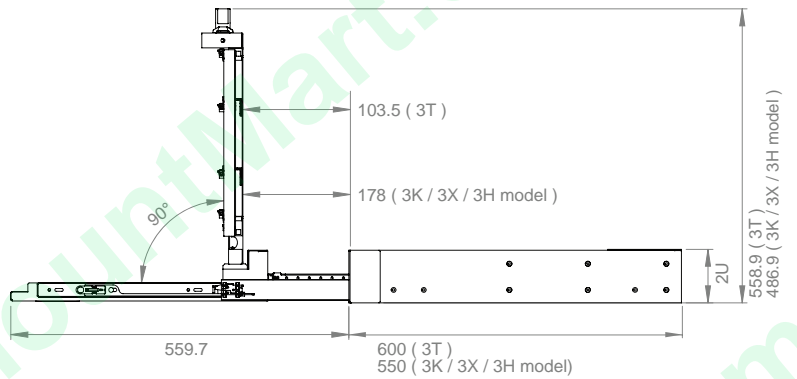

Rear View

LCD2U17-3K

Standard : DP
Option : DP + HDMI

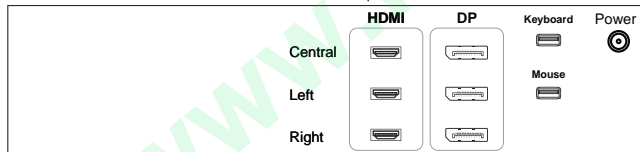

Add-on USB Selector

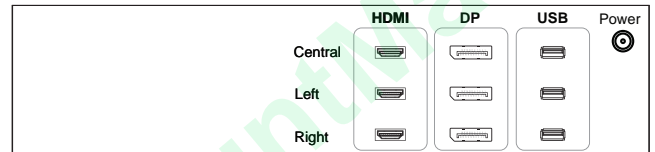

LCD2U17-3H

Standard : VGA + DVI-D
Option 1 : VGA + HDMI
Option 2 : VGA + DP

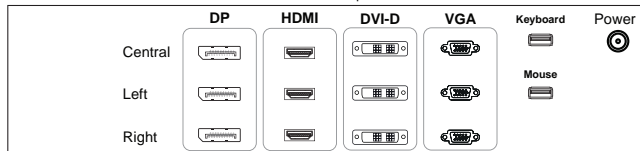

Add-on USB Selector

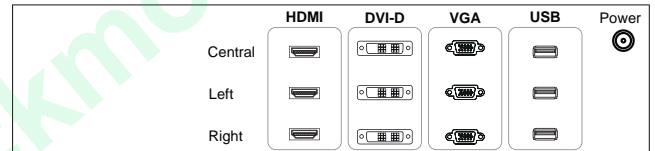

LCD2U17-3X / 19-3T

Standard : VGA + DVI-D
Option : VGA + HDMI

