

RA4016-6 Cabinet Top Fan Tray

This is a top fan tray fitted with 6 filtered fans and is designed for use with server cabinets.

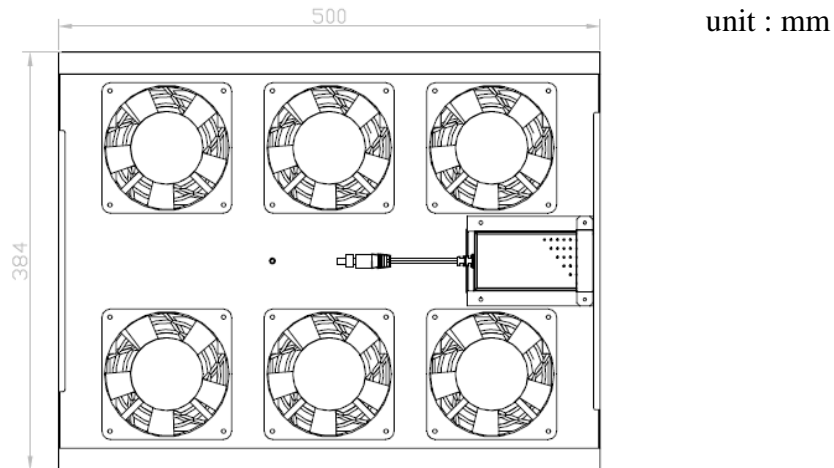

Features:

- Improved airflow and performance, enhance the natural convection airflow within a cabinet
- Fan tray with 6 filtered fans
- Includes power cord with IEC320 standard power socket

Technical Specifications:

- Motor Design – 2 phases, 4-poles Brushless DC motor
- Bearing System – Precision ball bearing system
- Direction of Rotation – Counter-clockwise viewed from front of fan blade
- 100~240 VAC 50/60 Hertz
- Rated Current – 451 mA per fan
- Rated Power Consumption – 5.4 WATTS per fan
- Operating Temperature Range: -10 to + 70 deg. C
- Storage Temperature Range: - 40 to + 70 deg. C
- Rated Speed – 3100 revolution per minute \pm 10% at rated voltage
- Air Flow – 108.2 cubic feet of air a minute per fan
- Static Pressure – 0.28 Inch-H₂O
- Acoustic Noise – 44.5 dB(A) per fan
- Dimension – H38.3 x W384 x D500mm
- Weight – 2.9 Kg
- Finish - Black