

Single Rail 20.1" LCD Console LCD1U20-01 User's Manual

SYNERGY GLOBAL TECHNOLOGY INC

www.RackmountMart.com

Toll : 1-888-865-6888

sales@RackmountMart.com

Packing List

The complete 20.1" LCD console package consists of:

- One 1U 19" rack mount console
- Two rail with front and rear bracket
- One 1.8 m KVM cable. (HDDDB-15 / VGA + PS/2 x 2) cable
- One power cord
- One user manual CD
- One quick installation guide
- Two keys
- Four flat screws. (for rail mount to console body)

Check to make sure that the unit was not damaged in shipping. If you encounter a problem, contact your dealer.

Please read this manual thoroughly, and follow the installation and operation procedures carefully to prevent any damage to the product, and / or any of the devices that connect to it.

Safety Instructions

1. Please read these safety instructions carefully.
2. Please keep this User's Manual for later reference.
3. Please disconnect this equipment from AC outlet before cleaning. Don't use liquid or sprayed detergent for cleaning. Use moisture sheet or clothe for cleaning.
4. For pluggable equipment, the socked-outlet shall be installed near the equipment and shall be easily accessible.
5. Please keep this equipment from humidity.
6. Lay this equipment on a reliable surface when install. A drop or fall could cause injury.
7. Do not leave this equipment in an environment unconditioned, storage temperature above 60 °C, it may damage the equipment.
8. The opening on the enclosure is for air convection hence the equipment from overheating. **DO NOT COVER THE OPENING.**
9. Make sure the voltage of the power source connect the equipment to the power outlet.
10. Please keep the power cord such a way that people can not step on it. Do not place anything over power cord. The power cord must rate for the voltage and current marked on the product's electrical ratings label. The voltage and current rating of the cord should be greater than the voltage and the current rating marked on the product.
11. All cautions and warning on the equipment should be noted.
12. If the equipment is not in use for long time, disconnect the equipment from mains to avoid being damaged by transient over-voltage.
13. Never pour any liquid into ventilation openings; this could cause fire or electrical shock.
14. Never open the equipment. For safety reason, qualified service personnel should only open the equipment.
15. If one of the following situations arises, get the equipment checked by service personnel.
 - The Power Cord or plug is damaged.
 - Liquid has penetrated into the equipment.
 - The equipment has been exposed to moisture.
 - The equipment has not worked well or you can not get it work according to User's Manual.

- The equipment has dropped and damaged.
- If the equipment has obvious signs or breakage.

Index of Contents

Packing List	I
Safety Instructions	II
Index of Contents	IV
1. General Information	1
1.1 Overview	1
1.2 Feature	2
1.3 Product Specification	3
1.3.1 20.1" LCD Console Specification	3
2. Panel Controls and OSD Function	5
2.1 Auto Tune	5
2.2 Input Source	5
2.3 Brightness	6
2.4 Contrast	6
2.5 Color	7
2.6 Position	7
2.7 Language	8
2.8 Recall	9
2.9 Exit	9
2.10 Power Indicator	9
3. Installation	10
3.1 Install 20.1" LCD Console into Cabinet	10
3.1.1 Notes	10
3.1.2 Hardware Kits Contents	10
3.1.3 Install Console Step	11
3.2 Installing the Video Card and Video Driver	12
3.2.1 Configuring the Display Settings	12
3.2.2 Connecting the Console	13
3.3 Turning on the Console	13
3.4 Testing the Console	13

1. General Information

1.1 Overview

The KVM console is an ideal solution for network administration with multiple servers / platforms. Their 15-inch and 17-inch 19-inch 20.1-inch large size TFT LCD color display and ultra-low-profile compact industrial keyboard / touchpad provide the user-friendliest and most reliable environment for network administrators. All these functions are integrated in a 19-inch 1U space with rugged construction design to achieve ultra space saving and high reliability for high quality industrial network applications.

The KVM console provide superior picture quality and state-of-the-art features mounted in an industrial grade, rack mount console. The console forms a rugged enclosure that protects the monitor from industrial hazards and permits easy access to monitor controls.

The KVM console monitors provide flicker-free color images at optimal resolutions. The monitors' 0.264mm pixel pitch ensures crisp images with clear definition, even at high resolutions. The KVM console monitors are intelligent, microprocessor-based, and have an ergonomically designed display.

The KVM console monitors employ the latest in active matrix thin film transistor (TFT) technology, providing crisp screen images and wide viewing angles. Unlike CRT monitors, LCD monitors are inherently immune to the magnetic fields commonly found on the plant floor or communications centers. LCDs are also typically brighter than conventional CRT technology, making them ideal for the high ambient lighting conditions found in many of today's factory environments. On-screen menus allow for display adjustments. In addition, the monitors' Plug-n-Play+ features support Windows 95/98,NT and XP, while a universal power supply ensures global applicability.

The KVM console monitors are compatible with most analog RGB (red, green, blue) display standards, including PS/2, optional for Sun Micro System, Apple Macintosh Centris, Quadra, and Macintosh II family signals. The LCD monitor is capable of displaying crisp and vibrant color graphics with VGA, S2GA, XGA (non-interlaced), and most Macintosh compatible color video cards.

1.2 Feature

- Single Rail easy to install and use
- Support DVI signal input
- Support 17 various keyboard languages
- Bright Active Matrix TFT Display
- OSD function (On Screen Display) for LCD display
- Durable keyboards
- Panel protected by tempered glass
- Support USB K/B , touchpad (optional)
- Audio Function (optional)
- DC power (optional)

1.3 Product Specification

1.3.1 20.1" LCD Console Specification

Number of ports	1
Dimension	662 x 443.7 x 43.5 mm / 26.0 x 17.5 x 1.7 inches
Package Dimension	843 x 571 x 226 mm / 33.2 x 22.5 x 8.9 inches
Display Size	20.1 inches
Panel Type	Active Matrix TFT LCD
Resolution Capabilities	Maximum Resolution up to 1600 x 1200 (UXGA)
Pixel Pitch	Supports 0.255 mm x 0.255 mm
Viewing Angle (CR>10)	Right-Left view 85°(Typ) Up-Down View 85°(Typ)
Contrast Ratio	1000 : 1
Brightness	White 300 cd/m ²
Back Light	Six Lamps for Back Light
Supported Colors	16.7M Colors (8-bit with FRC)
Response Time	Rising Time 15 ms, Decay Time 7 ms
Operating System	Dos, Windows (3.1, 9x, 2000, NT4, ME, XP, 2003 Server) Linux, Novell 3.12-6, HP UX, SUN
Multi Platform	Support PS/2 and USB
System Cables	VGA + PS/2 x 2 or VGA + USB x 1 cable
Keyboard Mouse	106 key PS/2 keyboard with touch pad
Sync	45 ~ 80 KHz
Power Source	100 ~ 240 VAC input
Power Consumption	50W, 45W for Panel
Temperature	Operate 0 ~ 50°C / 32 ~ 122°F Storage -20 ~ 60°C / -4 ~ 140°F
Humidity	10% ~ 90% RH
Chassis Construction	Heavy duty steel materials
Keyboard Language	USA, UK, German, French, Spanish, Italian, Portuguese, Dutch, Swiss, Belgium, Swedish, Norwegian, Danish, Japan, Taiwan, Russian, Hebrew
Certification	CE / FCC, UL / CUL / C-Tick, GOST

Table 1-1. 20.1" LCD Console Specification

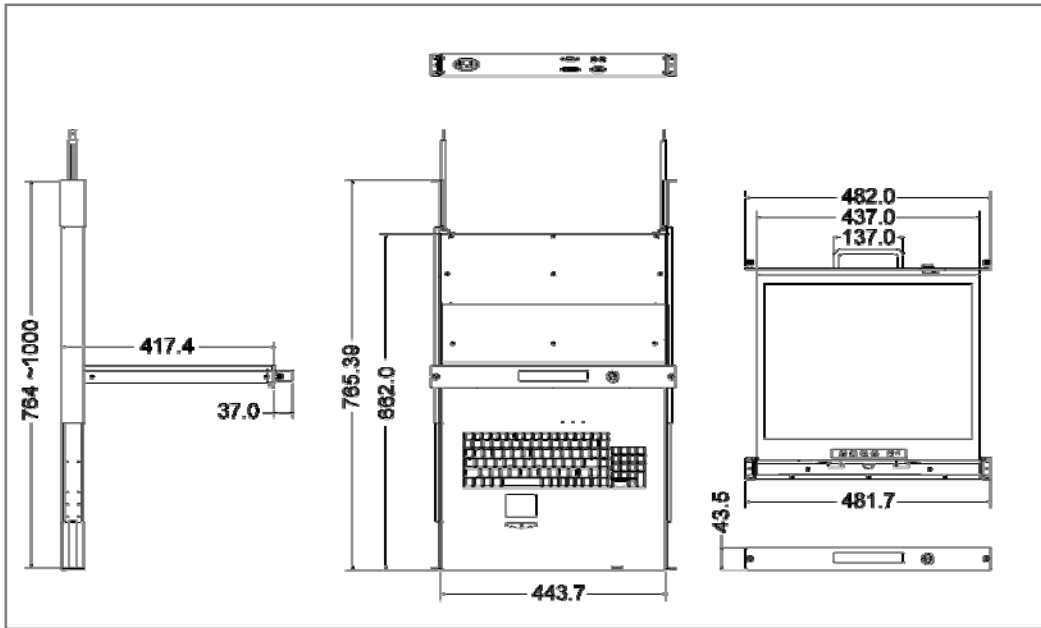

Figure 1-1. 20.1" LCD Console Dimension

2. Panel Controls and OSD Function



Controls	Description
	Soft power on/off button. Adjacent LED is lit when on.
Auto	Auto-synchronize and scale down display to any valid factory preset timings.
	Press to scroll the function you want to adjust.
	Press to scroll the function you want to adjust.
Menu	To access the main menu. This button also acts as the "Enter" button.

Table 2-1. Panel Controls

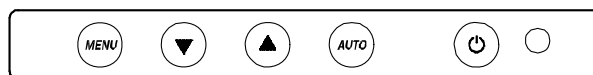

Figure 2-1. 20.1" LCD Console OSD Control bar

2.1 Auto Tune

Press the "auto tune" button. The panel will adjust the display size automatically and also tune the panel to its best condition.

2.2 Input Source

1. Press the "menu" button.
2. Use the "Down" and "Up" button to scroll.

Auto tune.

Input Source

Brightness

Contrast

Color

Position

Language

Recall

Exit

3. Press the "menu" button to enter, and you will see:

VGA / DVI

4. Use the "Down" and "Up" button to select the input source of signal.
5. Press the "menu" button to enter

2.3 Brightness

1. Press the "menu" button.
2. Use the "Down" and "Up" button to scroll.

Auto tune.

Input Source

Brightness

Contrast

Color

Position

Language

Recall

Exit

3. Press the "menu" button to enter.
4. Use the "Down" and "Up" button to adjust the brightness of the display.
5. Press the "menu" button to enter.

2.4 Contrast

1. Press the "menu" button.
2. Use the "Down" and "Up" button to scroll.

Auto tune.

Input Source

Brightness

Contrast

Color

Position

Language

Recall

Exit

1. Press the "menu" button to enter.
2. Use the "Down" and "Up" button to adjust the contrast of the display.

3. Press the "menu" button to enter.

2.5 Color

1. Press the "menu" button.
2. Use the "Down" and "Up" button to scroll.
 - Auto tune.
 - Input Source
 - Brightness
 - Contrast
 - Color**
 - Position
 - Language
 - Recall
 - Exit
3. Press the "menu" button to enter. And you will see:

Icon	Description
9300°K	To set CIE coordinates at 9300°K color
7500°K	To set CIE coordinates at 7500°K color
6500°K	To set CIE coordinates at 6500°K color
User	To set user defined CIE
Auto color	To auto adjust color
Return	To exit and return to the previous page

Table 2-2. Icon Description

4. Use the "Down" and "Up" button to adjust the color of the display.
5. Press "menu" to enter.

2.6 Position

1. Press the "menu" button.
2. Use the "Down" and "Up" button to scroll.
 - Auto tune.
 - Input Source
 - Brightness

- Contrast
- Color
- Position**
- Language
- Recall
- Exit

3. Press the "menu" button to enter. And you will see:

Icon	Description
Image Pos	To adjust the position of the image.
OSD Pos	To adjust the position of the OSD.
Return	To exit and return to the previous page

Table 2-3. Icon Description

- 4. Use the "Down" and "Up" button to scroll.
- 5. Press the "menu" button to enter.

2.7 Language

- 1. Press the "menu" button.
- 2. Use the "Down" and "Up" button to scroll.

- Auto tune.
- Input Source
- Brightness
- Contrast
- Color
- Position
- Language**
- Recall
- Exit

3. Press the "menu" button to enter. And you will see:

- English**
- German
- French
- Italian
- Spanish

4. Use the "Down" and "Up" button to scroll.
5. Press the "menu" button to enter.

2.8 Recall

1. Press the "menu" button.
2. Use the "Down" and "Up" button to scroll.

Auto tune.
Input Source
Brightness
Contrast
Color
Position
Language
Recall
Exit

3. Press the "menu" button to enter, and you will see:

Yes/ No

4. Select "Yes" button then "Menu" button to recall the factory setting.
Select "No " to return to the previous page.

2.9 Exit

Press the "exit" button to quit OSD menu.

2.10 Power Indicator

- ◆ GREEN ON
- ◆ RED STANDBY
- ◆ RED SUSPEND
- ◆ RED OFF

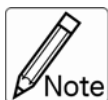

.....
OSD – On Screen Display
.....

3. Installation

3.1 Install 20.1" LCD Console Into Cabinet

3.1.1 Notes

1. Please check all peripherals according the list before installation. To make sure that the whole unit was not damaged and lost during shipping process. If you encounter any problem, please contact your dealer.
2. Before installation, make sure all peripherals and computer have been turned off.
3. Reliable earthing of rack-mounted equipment should be maintained. Particular attention should be given to supply connections other than direct connections to the branch circuit.

3.1.2 Hardware Kits Contents

1. Rail with front and rear bracket x 2.

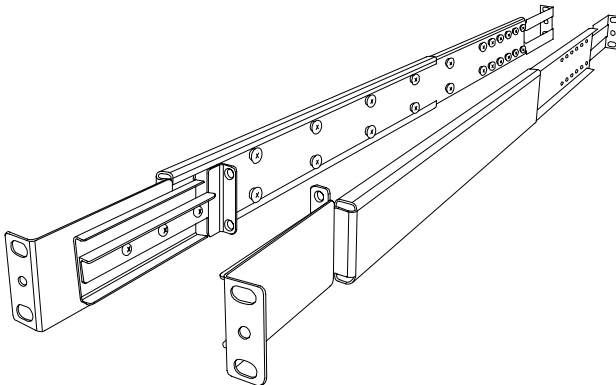

2. Screw (length = 6 mm) x 4



3. Key x 2



3.1.3 Install Console Step

1. Adjust rail with rear bracket to fit your cabinet

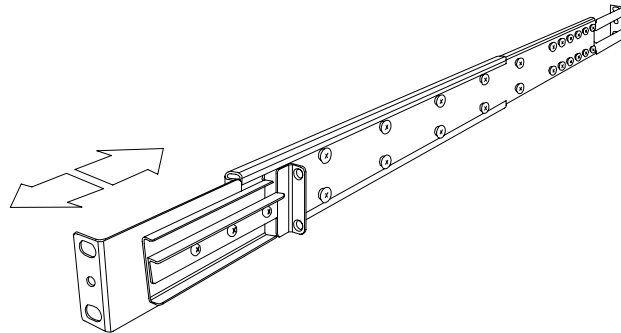

2. Install front and rear bracket on cabinet.

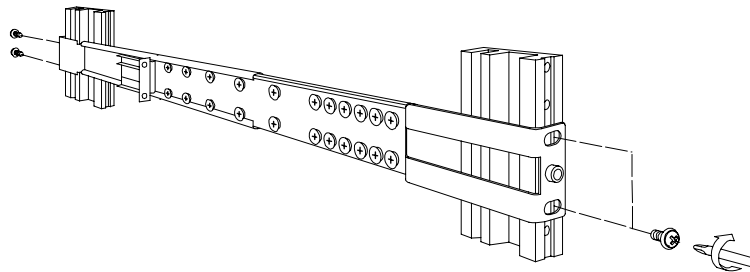

3. Repeat step 1~2 for the other side.

4. Push console into rails and push it to the end.

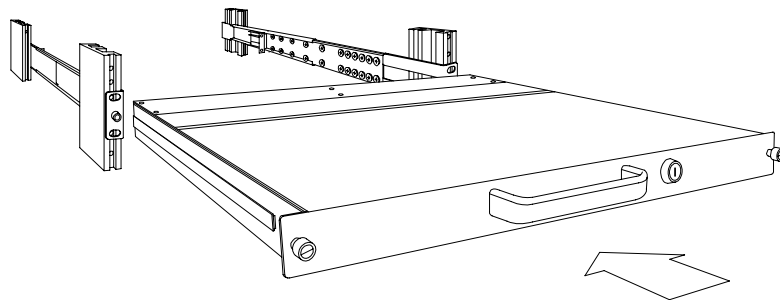

5. Install two screws (length = 6 mm) in rear of the console (Both sides) and finish installation.

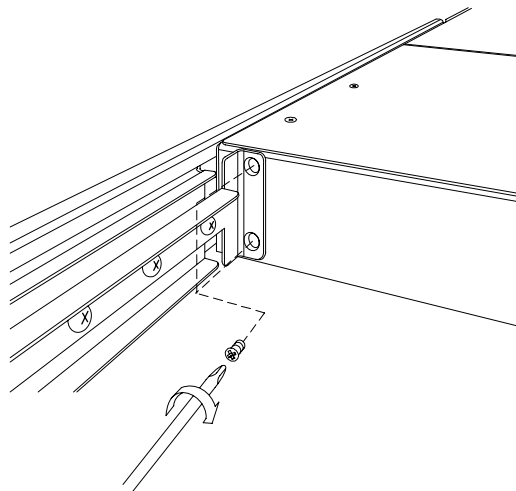

3.2 Installing the Video Card and Video Driver

Before connecting the LCD console, make sure your computer has a video card already installed for the monitor. After you connect the console, install the video software driver. The video driver is supplied by the video card manufacturer and may be found on the CD-ROM that came with your computer. If you need information on installing a video card or video driver, refer to the manual that came with your video card.

3.2.1 Configuring the Display Settings

After connecting the console and turning on your computer, you may need to configure one or more of the following display settings:

- Display mode (also called desktop area or video resolution)
- Refresh rate (also called vertical scan rate or vertical sync)
- Color depth (also called color palette or number of colors)

Each video card has several controls that let you adjust the display settings. However, the software and driver for each video card is unique. In most cases, you adjust these settings by using a program or utility provided by the manufacturer of the video card. Most video cards use the Windows Display Properties control panel to configure the display. To open the Windows Display Properties, click the right mouse button in a blank area of the Windows desktop and then select **Properties**. The Settings tab usually lets you change the Color Palette and the Desktop Area (*x by y pixel resolution*).

Some video cards integrate additional features into the Windows Display Properties control panel to give you an exceptional setup that is flexible and easy to use. For example, the control panel may include an Advanced Properties button, an Adjustment tab, or a Refresh tab for changing other settings. Other video cards have a separate utility for setting display properties.

Whenever you change the resolution, color, or refresh rate, the image size, position, or shape may change. This behavior is normal. You can readjust the image using the monitor on-screen controls. For more information on the monitor on-screen controls, refer to Chapter 2. For more information on configuring the display settings, refer to the manual that came with your video card.

3.2.2 Connecting the Console

To connect an LCD console to a computer, perform the following steps



Figure 3-1. The rear view of LCD console

1. Turn off your computer. You should always turn off your computer before connecting or disconnecting a device.
2. Connect the video (VGA) connector of the KVM cable to the video card connector on the rear panel of your computer.
3. Identify and connect the PS/2 mouse and PS/2 keyboard connector to the correct PS/2 ports on the rear panel of your computer.
4. Connect the Power cord to the power inlet on the console and then to a power outlet.

3.3 Turning on the Console

Make sure all cables and the Power cord are connected properly. Be sure to tighten all connector screws. Using two hands, grasp the rear of the console, lift the tab and pull the panel up and forward. This will disengage the momentary on / off switch and the unit should power on. The LED on the left or under of the monitor panel should turn from orange to green, verifying that the unit is operational.

3.4 Testing the Console

To test that the console is working properly, perform the following steps:

1. Power up the console, and then turn on your computer.
2. Make sure the video image is centered within the screen area. Use the OSD controls to adjust the image (see note below) or press the Auto button on the right hand side of the monitor.



.....
If the unit does not power up when the panel is pulled up, try pushing the soft power on/off button on the left or under side of the monitor panel to power up the unit.
.....



You can adjust the horizontal and vertical position, contrast, and brightness to better suit your video card and your personal preference. Refer to Chapter 2 for more information on using the on-screen menu to adjust the video display.

Before you begin, make sure that powers to all the devices you will be connecting up have been turned off. To prevent damage to your installation due to ground potential difference, make sure that all the devices on the installation are properly grounded. Consult your direct vendor for any technical issues if necessary.

SYNERGY GLOBAL TECHNOLOGY INC

www.RackmountMart.com

Toll : 1-888-865-6888

sales@RackmountMart.com

Single Rail 20.1" LCD Console

User's Manual