



Toll Free: 1-888-865-6888

Tel: 510-226-8368 Fax: 510-226-8968

Email: sales@RackmountMart.com

LCD1U17-47 User Manual



This manual, covering various aspects of the equipment such as installation, setup and cascade, will help you make full use of this LCD KVM Drawer. Please read this manual carefully and install and operate the equipment according to the manual to avoid damage to this product its accessories.

Product package includes following items:

- 1 * 17.3 inch LCD KVM Drawer;
- 1 * AC Power Cord
- 1 * Rack installation bracket (one pair)
- 1 * USER'S manual (CD)
- 1 * 1.8 Meter HDMI cable
- 1 * 1.8 Meter Display port cable
- 1 * 1.8 Meter USB A Type cable

Please check items above. If any item is missing or damaged, please contact your dealer promptly.

Table of Contents

1	Introduction	-4-
	1.1 Overview	-4-
	1.2 Functions & Features	-4-
	1.3 Hardware Requirement	-4-
	1.3.1 Host Requirement	-4-
	1.3.2 Cables	-4-
	1.4 Product Specifications	-5-
	1.5 LCD Specifications	-5-
	1.6 Front View	-6-
	1.7 Rear View	-7-
2	Installation	-8-
	2.1 Rack Installation	-8-
	2.2 Standard Installation	-9-
	2.3 LCD OSD Menu Setup	-10-
3	Certificates	-11-

1 Introduction

1.1 Overview

The LCD integrates keyboard, LCD display and touch pad in a drawer type worktable and provides a convenient space-saving operation mode for KVM switch technology. The cover is an LCD display, while the base is keyboard and touchpad.

This console is a control device integrating 17.3" LCD, 104 keys keyboard and touchpad mouse. You can access multiple hosts using the LCD console while saving money and efforts.

LCD KVM console is the best choice to save time and efforts. Since all hosts can be controlled from a single main control terminal, using the LCD Console:(1)avoids the cost of keyboard, mouse and monitor of each host; (2) saves work space; (3) saves power; (4) saves the trouble of moving from one computer to another.

* For Mac and Sun hosts, USB cable must be used for connection.

1.2 Function & Features

The LCD console is integrated to a drawer type worktable of 1U height to facilitate rack installation. Supported resolution up to 3840 x 2160. It meets the 1U height of rack specifications and can be installed into 19 inch rack cabinet . No need to install additional software or hardware.

1.3 Hardware Requirement

1.3.1 Hosts Requirement:

- (1) DP, HDMI graphic card

Note: the max. resolution of the integrated LCD display is 3840 x 216, @60Hz. Make sure the resolution of any connected computer does not exceed this resolution.

- (2) USB port for keyboard and mouse.
- (3) USB 2.0 Hub for peripheral USB device

1.3.2 Cables

- (1) HDMI cable male to male
- (2) Display port Cable male to male
- (3) USB A Type Cable

1.4 Product Specifications

Model		4K-LCD-console
Brightness		400cd/m2
Contrast		1000:1
Angle of visibility		178°(H),178°(V)
Color display		16.7M
Keyboard		104 keys
Mouse		touch pad mouse
Local Control Terminal	Keyboard/Mouse	USB 2.0
	HDMI2.0	HDMI female connector (HDCP2.2)
	Display port 1.4	Display port female connector (HDCP2.2)
	USB 2.0	For USB peripheral device
Video resolution		3840 x 2160 @ 60Hz 1920 x 1200 @ 60Hz 1920 x 1080 @ 60Hz
Power supply		100-240V AC 50/60Hz via IEC Type power cord
Housing		Metal housing
Weight		9.7Kg
Dimension(W x H x D)		443 x 42 x 406 (mm)

1.6 Front View

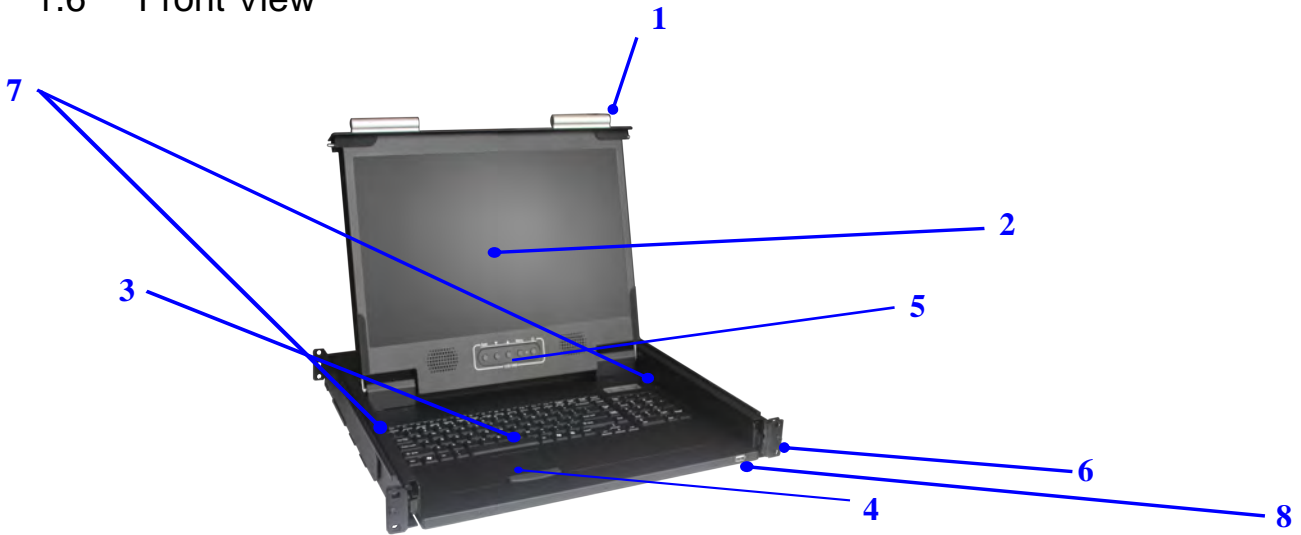

NO	Part	Function Description
1	Handle to adjust screen position	
2	LCD display	
3	Keyboard	
4	Touchpad	
5	LCD OSD button	LCD button to control Screen Display position and image setting.
6	Mounting bracket	Install into rack cabinet
7	Lock button	Auto lock / release when lcd pull up and down
8	USB2.0 HUB port	

1.7 Rear View

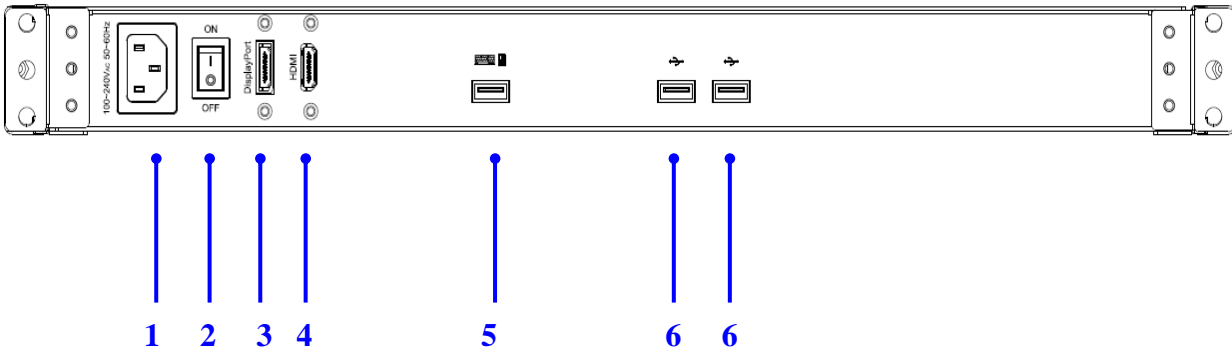

No	Component	Function Description
1	AC Power port	Standard IEC Type AC Inlet
2	Power Switch	Rock switch, turn on/off equipment main power.
3	Display port	Connect to server.
4	HDMI port	Connect to server.
5	USB port	Connect to server.
6	USB 2.0	For USB peripheral device

2 Installation

2.1 Rack Installation

Step 1

Attach the two rear slide rails to the rear vertical mounting rails of the rack cabinet using standard M6 cage nuts and screws (2 pcs).

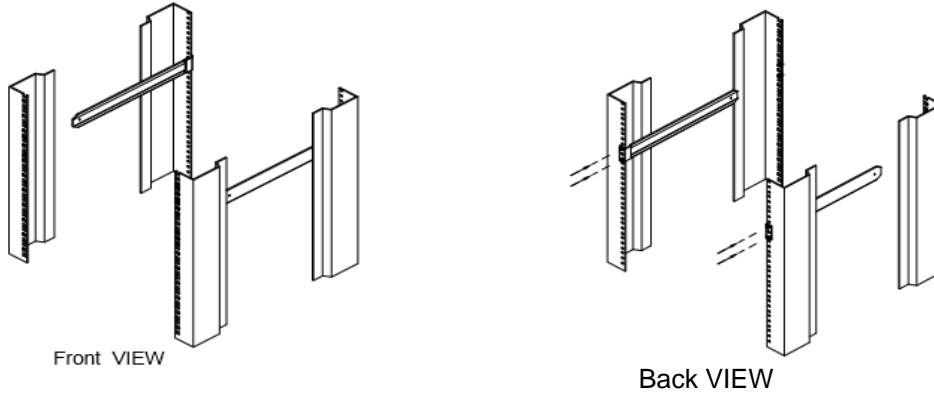

Step 2

Attach the two front slide rails to the front vertical mounting rails of the rack cabinet using standard M6 cage nuts and screws (2 pcs).

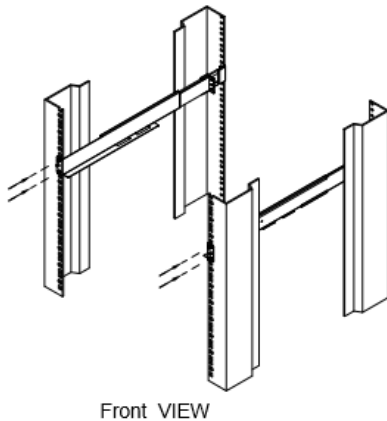

Step 3

Position the LCD console drawer so the two slide rails will hold on the main body of the LCD console drawer. Stable the mounting ears of LCD console drawer by #6-32 cage nuts and screws (front: 2 pcs; rear: 4 pcs).

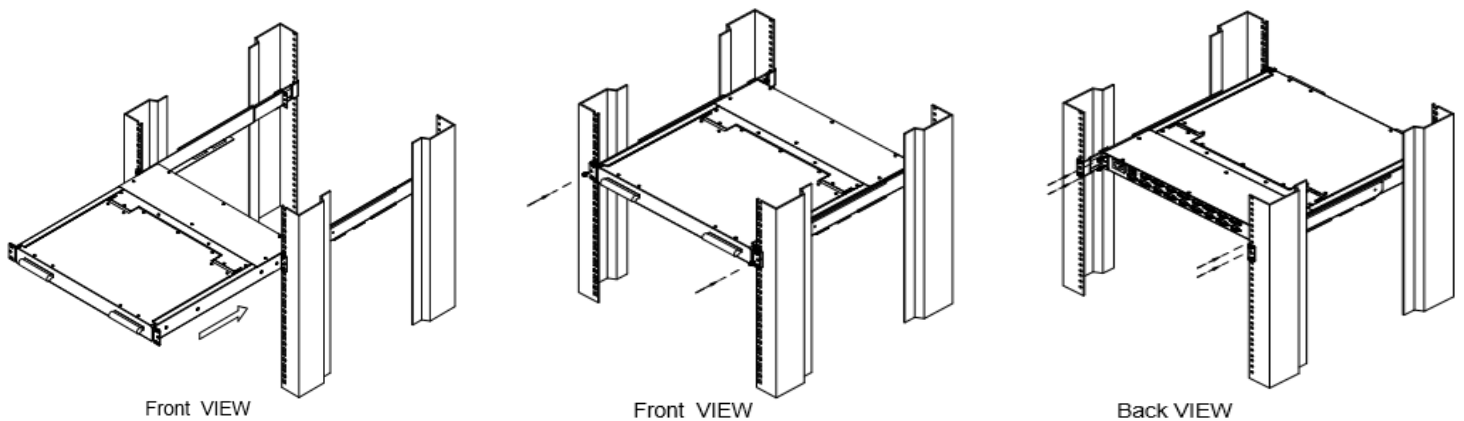

2.2 Standard Installation

Please follow the installation drawing and instructions below for standard installation:

- * Please Shutdown the Power of Equipment Needs to be Connected
- * Please Pay Attention to Earthing of Equipment

The standard installation is completed, and LCD KVM console can be powered on. Then power on connected hosts.

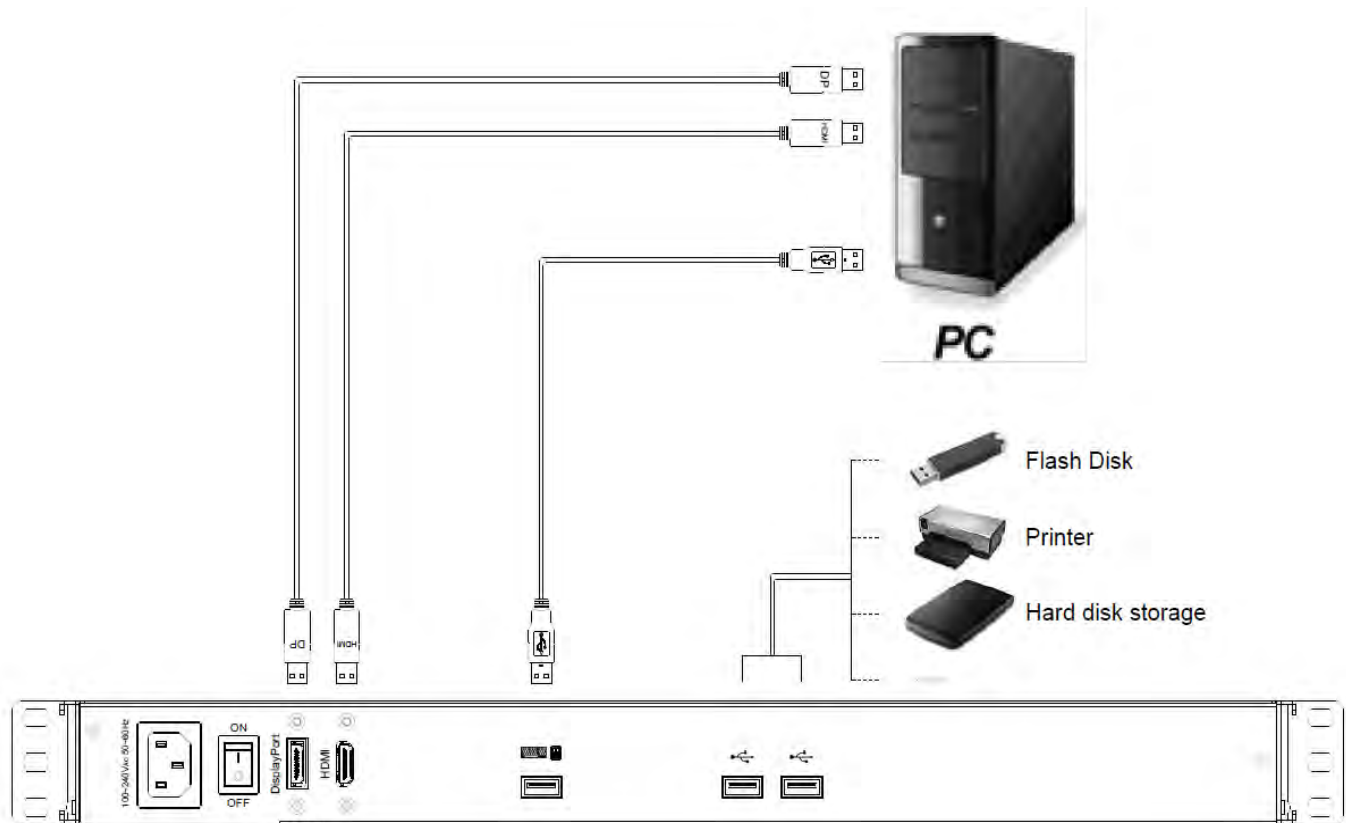

REAR-COVER

2.3 LCD OSD Menu Setup

OSD Control buttons

LCD OSD can establish and setup LCD display. Setup instructions of four buttons are as follows:

Button	Functions
POWER	Turn on or off the LCD Display
MENU	Activate OSD menu, select a menu and press MENU key to confirm the selection and enter the submenu.
▲	Press this key to increase setting or scroll up the menu bar
▼	Press this key to Decrease setting or scroll down the menu bar
Auto/Source	Auto screen adjustment

3 Certificates

FCC

This product has been tested and is proved to meet requirements of Grade B electronic devices and specifications of Section 15 of FCC certification. Please observe following two conditions in operation that:

- (1) The equipment will not generate any harmful interruption.
- (2) If the equipment is interrupted, it may cause unnecessary operations.

CE

This equipment complies with regulations of EN55022:CLASS B.

RoHS

The whole package including products, packaging materials and documents meet RoHS equipments.

The company reserves the right to modify product specifications without prior notice and assumes no responsibility for any error which may appear in this publication.

All brand names, logo and registered trademarks are properties of their respective owners.

Copyright 2020 Synergy Global Technology Inc. All rights reserved.